

Scenario Liebertwolkwitz 14 October 1813

This scenario is closely based upon the one designed by Paul Edgar and posted to the **napsbattles** group of yahoo.

Saxony, October 1813. Napoleon's *Grande Armee* is concentrating around Leipzig in anticipation of a major action against the combined allied armies. On the 14th, the leave elements of Schwarzenberg's *Army of Bohemia* appear to the South of the French positions. Needing more time to assemble his forces, Napoleon orders Murat to fight a delaying action around the village of Liebertwolkwitz. Meanwhile Wittgenstein, leading the advance guard of the allied army, believes that he has caught the rearguard of the retreating French, and quickly deploys believing that he needs to bring them to battle before they slip away.

1 MAP: The Liebertwolkwitz Battlefield.

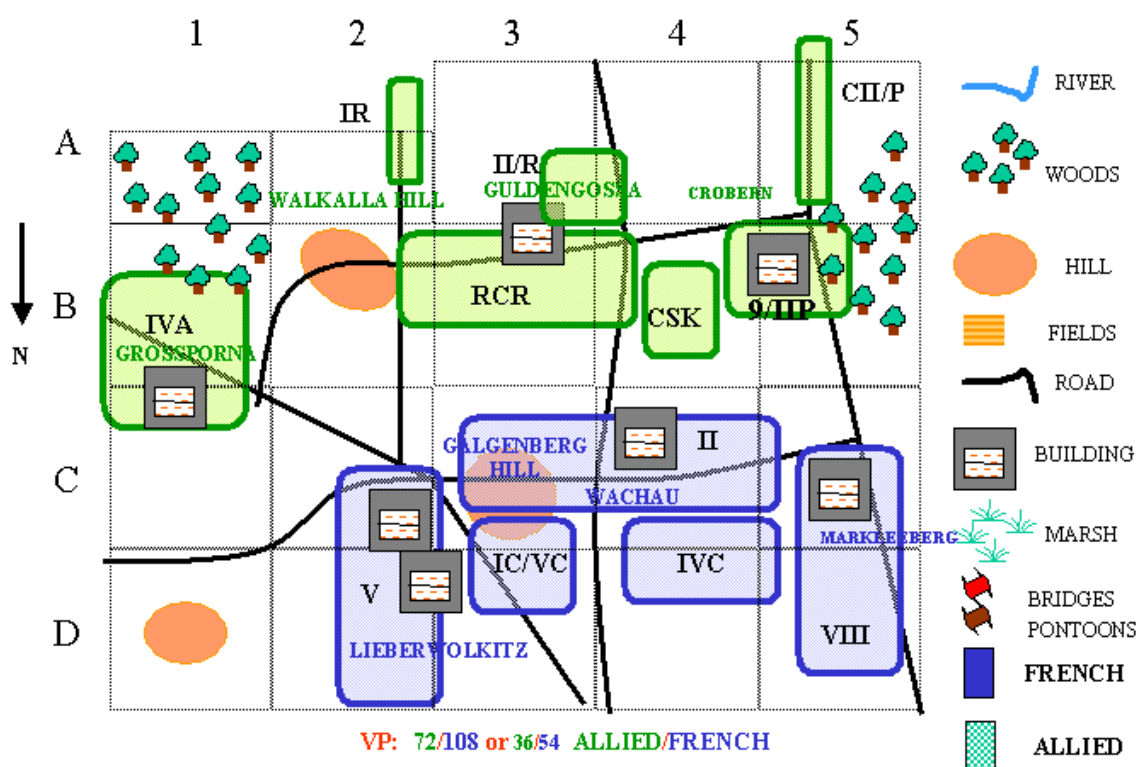

MAP NOTES:

- 1.1: All buildings have a "+3" combat modifier.
- 1.2: The river (the Pleisse) is unfordable and runs through the column 5. All units may cross it only at the bridge located in the D5 road .
- 1.3: The French on-table forces set up first. The Allied forces set up second, and may set up as close as 12 inches (30 cm) from the French forces

2 ORDER OF BATTLE (Cavalry reduced at 80/120 rate)

FRENCH

(4) GRANDE ARMÉE (F) Marshal Murat, Prince of Naples 35(23)E(10)+2 [18M] [13F]

The second command span is for combat units only

(2) II CORPS (II) Victor 20 G(5)+1 [5F]

(1) FOURTH DIVISION (4/II): Dubreton: 10 E(7)+0

1B/4/II: 24 FrLT [12D] 2B/4/II: 24 FrLN [12D]

(1) FIFTH DIVISION (5/II): Dufour: 8 P(5)+0

1B/5/II: 16 FrLT [8D] 2B/5/II: 20 FrLN [10D]

(1) SIXTH DIVISION (6/II): Vial 1: 8 A(6)+0

1B/6/II: 24 FrLN [12D] 2B/6/II: 24 FrLN [12D]

(1) TWENTY-SECOND LIGHT CAVALRY BRIGADE (22L/IIIC): Bruno 8 A(6)+0

1B/22L/IIIC: 8 WtLC [3D]

CORPS ARTILLERY (II): II: Fr 12# II: Fr 12# II: Fr 6# II: Fr 6#

(2) V CORPS (V) Lauriston 20 G(5)+1 [4F]

(1) TENTH DIVISION (10/V): Albert: 8 G(8)+1

1B/10/V: 28 FrLN [14D]

(1) SIXTEENTH DIVISION (16/V): Maison: 10 G(8)+1

1B16/V: 28 FrLN [14D]

(1) NINETEENTH DIVISION (19/II): Rochambeau 2: 10 A(6)+1

1B/19/V: 16 FrLN [8D] 2B/19/V: 16 FrLN [8D]

(1) SIXTH LIGHT CAVALRY BRIGADE (6L/VC): Dermoncourt: 8 A(6)+0

1B/6L/VC: 8 FrLC [4D]

CORPS ARTILLERY (V): V: Fr 12# V: Fr 12# V: Fr 6#

(2) VIII CORPS (VIII) Poniatowski 25 G(7)+1 [4F]

(1) TWENTY-SIXTH DIVISION (26/VIII): Kamiencki: 8 G(5)+1

1B/26/VIII: 20 PdLN [8D] 2B/26/VIII: 24 PdLN [10D]

(1) TWENTY-SEVENTH LIGHT CAVALRY BRIGADE (27L/VIIIC): Uminski: 10 G(6)+1

1B/27L/VIIIC: 8 PdKRC [3D]

CORPS ARTILLERY (VIII): VIII: Pd 12#

(2) I CAVALRY CORPS (IC) Latour-Mauborg: 15 G(6)+1 [4F]

(1) FIRST LIGHT CAVALRY DIVISION (1C/IC): Berckheim: 10 A(5)+0

1B/1C/IC: 8 FrLC [4D]

(1) THIRD LIGHT CAVALRY DIVISION (3C/IC): Chastel: 10 G(5)+0

1B/3C/IC: 8 FrLC [4D]

(1) FIRST CUIRASSIER DIVISION (1CC/IC): Bordesoulle: 10 A(6)+0

1B/1CC/IC: 8 FrHC [4D] 2B/1CC/IC: 8 SxHC [2D]

(1) THIRD HEAVY DIVISION (3H/IC): Doumerc: 10G(7)+1

1B/3H/IC: 8 FrHC [4D] 2B/3H/IC: 8 FrDC [3D]

CORPS ARTILLERY (IC): IC: Fr 6# IC: Fr 6# IC: Fr 6# IC: Fr 6# IC: Sx 6#

(2) IV CAVALRY CORPS (IVC) Sokolnicki: 15 G(6)+1 [2F]

(1) SEVENTH LIGHT CAVALRY DIVISION (7C/IVC): Tolinski: 8 A(5)+0

1B/7C/IVC: 10 PdLC [4D]

(1) EIGHTH LIGHT CAVALRY DIVISION (8C/IVC): Sulkowski: 10 A(5)+0

1B/8C/IVC: 10 PdLC [4D]

CORPS ARTILLERY (IVC): IVC: Fr 6# IVC: Pd 6# IVC: Pd 6#

(2) V CAVALRY CORPS (VC) Pajol: 13 G(6)+1 [3F]

(1) NINTH LIGHT CAVALRY DIVISION (9C/VC): Subservie: 8 G(5)+1

1B/9C/VC: 8 FrLC [4D] 2B/9C/VC: 8 FrLC [4D]

(1) FIFTH HEAVY CAVALRY DIVISION (5H/VC): Heritier: 10 G(6)+1

1B/5H/VC: 10 FrDC [4D]

(1) SIXTH HEAVY CAVALRY DIVISION (6H/VC): Milhaud: 8 G(7)+1

1B/6H/VC: 10 FrDC [4D]

CORPS ARTILLERY (VC): VC: Fr 6#

ALLIED

(4) ARMY OF BOHEMIA (B) Schwarzenberg 50(27) A(10)+0 [20M] [13F]
The second command span is for combat units only

(2) PRUSSIAN II CORPS (IIP): Kleist 2: 23 G(7)+1 [5F]

(1) NINTH BRIGADE (9/IIP) Klux: 8 P(4)+0

1B/9/IIP: 16 PrLN [8D] 2B/9/IIP: 16 PrRES [8D]

(1) TENTH BRIGADE (10/IIP) Pirch 1: 10 G(7)+1

1B/10/IIP: 16 PrLN [8D] 2B/10/IIP: 16 PrSLW [10D]

(1) ELEVENTH BRIGADE (11/IIP) Carnall: 8 A(4)+0

1B/11/IIP: 16 PrLN [8D] 2B/11/IIP: 16 PrRES [8D]

(1) TWELFTH BRIGADE (12/IIP) Preussen: 8 A(4)+1

1B/12/IIP: 16 PrLN [8D] 2B/12/IIP: 16 PrLN [8D]

(1) CORPS CAVALRY (C/IIP) Roder: 10 G(6)+1

1B/C/IIP: 10 PrHC [4D] 2B/C/IIP: 8 PrLWC [5D]

(1) CORPS ARTILLERY (IIP) IIP: Pr 12# IIP: Pr HFA IIP: Pr 6# IIP: Pr 6#

(3) RUSSIAN WING (RW): Wittgenstein: 33 G(6)+1

(2) RUSSIAN I CORPS (IR): Gortchakov 1: 18 G(5)+1 [2F]

(1) FIFTH DIVISION (5/IR) Mesenzov: 8P(4)+0

1B/5/IR: 16 RsLN [8D] 2B/5/IR: 16 RsJG [8D]

(1) FOURTEENTH DIVISION (14/IR) Helfrich: 8 G(6)+0

1B/14/IR: 16 RsLN [8D]

(1) CORPS ARTILLERY (IR) IR: Rs 12# IR: Rs 12# IR: Rs 12# IR: Rs 12# IR: Rs 6# IR: Rs 6# IR: Rs 6# IR: Rs 6#

(2) RUSSIAN II CORPS (IIR): Eugene: 20 G(7)+1 [1F]

(1) THIRD DIVISION (3/IIR) Chakhovsky: 3" A(4)+0

1B/3/IIR: 20 RsLN [10D]

(1) FOURTH DIVISION (4/IIR) Puchinzk: 8 A(4)+0

1B/4/IIR: 20 RsLN [10D]

(1) CORPS ARTILLERY (IIR) IIR: Rs 12# IIR: Rs 12# IIR: Rs 12# IIR: Rs 12# IIR: Rs 12# IIR: Rs 12# IIR: Rs 12# IIR: Rs 6# IIR: Rs 6# IIR: Rs 6# IIR: Rs 6#

(1) COSSACK CORPS (CSK): Platov: 15 E(7)+2 [3F]

1B/CSK: 10 RsCLC [7D] 2B/CSK: 10 RsCLC [7D] 3B/CSK: 8 RsCLC [6D] 4B/CSK: 12 RsCLC [8D]

5B/CSK: 10 RsCLC [7D] CSK: Rs 6# CSK: Rs 6#

(3) AUSTRIAN IV CORPS (IVA): Klenau: 20G(6)+1 [7F]

(1) SECOND LIGHT DIVISION (2L/IVA) Bubna: 10 G(8)+0

1B/2L/IVA: 24 AsGRZ [14D] 2B/2L/IVA: 16 AsJG [8D] 3B/2L/IVA: 10 AsLC [5D] 4B/2L/IVA: 12

AsLC [6D] 2L/IVA: As 6# 2L/IVA: As 6#

(1) FIRST DIVISION (1/IVA) Mohr: 10 A(6)+0

1B/1/IVA: 24 AsGRZ [14D] 2B/1/IVA: 8 AsLC [4D]

3B/1/IVA: 8 AsLC [4D] 1/IVA: As 6# 1/IVA: As 6#

(1) SECOND DIVISION (2/IVA) Bartenstein: 8 G(4)+0

1B/2/IVA: 16 AsLN [10D] 2B/2/IVA: 20 AsLN [12D] 3B/2/IVA: 20 AsLN [12D]

(1) THIRD DIVISION (3/IVA) Mayer: 8 A(5)+0

1B/3/IVA: 24 AsLN [14D] 2B/3/IVA: 24 AsLN [14D] 3B/3/IVA: 8 AsHC [3D]

(1) CORPS ARTILLERY (IVA) IVA: As12#

(2) RUSSIAN RESERVE CAVALRY CORPS (RCR): Pahlen: 13 G(7)+1 [3F]

(1) LIGHT CAVALRY DIVISION (LC/RCR) Lissanevitch: 8 A(6)+0

1B/LC/RCR: 8 RsLC [4D] 2B/LC/RCR: 12 RsCLC [8D] 3B/LC/RCR: 10 RsCLC [7D] LC/RCR: Rs 6#

LC/RCR: Rs 6#

(1) DETACHED CAVALRY BRIGADE (D/RCR) Zeiten: 10 G(8)+1 (See note a)

1B/D/RCR: 8 PrLC [4D] 2B/D/RCR: 8 PrLC [4D] D/RCR: Pr 6#

Notes: a: Detached from the IIP Corps, and Kleist 2 may also control this unit as Corps commander.

4 SPECIAL RULES

4.1 Game Length: 1130-1630 hours (11 Turns). The French are the First Side.

4.2 Arrival Times: There are no reinforcements in standard scenario.

The Prussian II Corps deploy with 9/IIP on board as indicated. C/IIP deploy on board in march column.

Subsequent brigades move on board in continuous march column following C/IIP via the A5 road.

The Russian II Corps deploys as indicated in continuous march column. Subsequent brigades enter in continuous march column at the A2 road entry.

4.3 Changing Weather: weather is fine at the commencement of the action.

4.4 Options: France starts with the Initiative. The French get 5 free rolls, the Allies 3 free roll markers.

4.5 Shaky French Allies (Optional): Historically, a number of France's German allied units defected to the Coalition side during the campaign. If any Saxon or Wurtemberg unit(s) are placed in a situation where it would be considered isolated (see 15.5 in the Rule Booklet), the unit will *immediately* (when their isolation is pointed out during the Isolation Phase) "defect". A unit that defects is considered eliminated on the French side (for fatigue and army morale), but can be added to the Coalition side (no effects on fatigue or army morale). Add a defecting unit to any Coalition division and/or corps that had a unit(s) involved in the defecting unit(s) isolation. It may be moved, fire and/or engage in combat as a normal Coalition unit during all phases following the defection.

5 VICTORY POINTS:

Wachau, each building in Liebertwolkwitz, Grossposna, Guldengossa, the Galgenberg Hill and the Walkalla Hill are each worth 72/108 French / Allied victory points. Markkleeberg and Crobern are worth 36/54 French / Allied victory points.

Markkleeberg, Wachau, Liebertwolkwitz and the Galgenberg Hill are considered to be French controlled at the game's start. Grossposna, Crobern, Guldengossa and the Walkalla Hill are considered to be Allied controlled.

6 HISTORICAL NOTES:

Pahlen, lead the initial Allied cavalry attack. He was surprised when the French 'rearguard' cavalry turned and deployed for battle in considerable numbers. A series of running cavalry actions followed during the late morning and early afternoon around Wachau and Markkleeberg.

At 2:00pm the Austrian IV Corps under General Klenau stormed Liebertwolkwitz, taking the whole town with the exception of the church. With the cavalry action proving inconclusive and darkness approaching, Murat led forward the infantry of the II and V Corps about 4:00pm. The divisions of Albert and Rochambeau forced the Austrians to retire from Liebertwolkwitz. The action ceased around 4:30 with only minor skirmishing continuing into the evening.

Losses totalled about 2000 on each side.

7 DESIGN NOTES

Points French 910 : Allies 1144

As Napoleon is present in the field (although he does not command) all French/allied units increase their Dispersal category in 1: C becomes B....

Sources and Design (Paul Edgar *dixit*):

I managed to locate three detailed maps from the Austrian War Archive. These represented the action during its various phases. The scenario map is based upon these maps, and so differs in detail from the same ground in the Napoleon's Battles Leipzig Scenario. Several accounts of the action were available in histories of the Leipzig Campaign. None were fully detailed, and several included contradictions as to the units present. The Austrian maps provided significant detail upon the units present and their deployment, so these formed the prime source of the order of battle, in association with o-o-bs for Leipzig.

Play and Play Balance:

This scenario was originally developed for the 2002 Group North gaming weekend. In the initial version the allies started with the majority of the victory points. At the suggestion of the play testers this was altered to even the balance of victory points held by each side at the start. As a result, either side may choose to sit on the defensive, and if both choose to then the game will probably result in an unspectacular draw. It will require both sides adopt an 'aggressive' style of play to emulate the historic action.

Historic Outcome:

France: 448 – Allies: 448

Feedback: If you play this scenario, I would be interested in feedback, specifically: _ How well it played and any issues or clarifications that arose during play_ The result (ie minor French win, major Austrian win, draw, etc and victory point totals)_ Any suggestions regarding improvement of the scenario (within its historical context obviously) Paul Edgar

Stoli@arcom.com.au

NOTES

a For infantry in square, use the other (OT) modifier if vs. any infantry. For infantry not in square, use the “OT” modifier if vs. any attacking cavalry, and not in a town, entrenched, or with friendly cavalry in the same combat. For attacking cavalry, use the “OT” modifier vs. infantry or artillery not in square and not in a town, entrenched, or with friendly cavalry in the same combat. Use the current modifier in all other combats.

b The “RSP (Response) number is used for cavalry recalls (with a “-1” modifier for Austrian HC and LC , a “-4” for british (not KGL) and “-2” for all other cavalry), rallying and for square (with a “+1” for Prussian GD, GN and LN in line formation until 1809, “+2” for Austrian GN and LN in column formation after 1807, and “+1” for all other infantry in column formation. General RSP modifiers are: “-1” if Poor, “+1” if Good and “+2” if Excellent. The disorder modifier is “-3”. A modified RSP number is also the withdrawal modifier.

c **ROUTS** Infantry and gunners 46 cm, cavalry and limbered artillery 69 cm. Routing units always in column or limbered

d Subtract for the “LIN or UNL” speed. Also the cost to “about face”. Cannot used while within 3 cm of an enemy unit

e Eliminated on “1-3” when alone or attached to a routed, dispersed or eliminated unit

f Use the current formation modifier

g May evade infantry (horse artillery limbers, if not so when contacted) unless disordered or routed. Only reacting cavalry may evade enemy cavalry

h May dismount

i Same as when mounted

j Can all-out attack Number = army morale value

k Two fire hits from one shoot or One combat hit are required to eliminate an artillery, pack train or wagon crew figure (also disorders the unit). Any artillery, pack train or wagon is eliminated with two eliminated crew

l Use a “-1” modifier for artillery representing only 4-5 guns. Gunners without their gun lose their ability to fire

m Per 4 cavalry or infantry bases or per 1 artillery, pack train or wagon base. 1 point less for batteries of only 4-5 guns

n 10-12 gun batteries (usually Russian) are represented by two separate artillery bases

p May not initiate combats

q May initiate combats only if attached to infantry or cavalry

s Is skirmish infantry

3 LIEBERWOLKITZ INFORMATION CHART

Country	Unit	Name	COMBAT MODIFIERS										MOVEMENT MODS					
			Col or LIM	LIN or ULM	SQ vs CAV	Vs OT a	DRD	ROUT NUM r	RSP	DSP b	FIRE	MOD 1	Col or LIM	LIN or ULM	MRCH COL	RGH OR SQR	BCK OR SID	CHG FOR d
~	GEN	General eq	~	~	~	~	~	~	~	~	~	~	~	90	~	2/1	1/1	~
~	MES	Messenger ep	~	~	~	~	~	~	~	~	~	~	~	90	~	2/1	1/1	~
~	WAG	Wagon/Pack Train p	-7	~	~	f	f	f	k	k	3	~	25	~	35	6/1	~	~
~	DCV	Dismounted Cavalry	-3	-2	+3	-7	I	I	I	I	5	-4	13	3	38	2/1	3/1	3
French	HC	Heavy Cavalry	+1g	+2g	~	+5	2	4	6	C	~	~	33	30	53	4/1	3/1	17
French	DC	Dragoon Cavalry** h	-1g	+1g	~	+4	2	3	6	B	~	~	38	35	55	3/1	2/1	15
French	LC	Light Cavalry h	-2g	0g	~	+4	2	3	6	C	~	~	38	35	55	3/1	2/1	17
French	LN	Line Infantry	-2	+1	+6	-5	2	3	5	C	10	0	23	3	40	3/1	3/1	3
French	LT	Light Infantry	-2	+1	+6	-5	2	3	5	C	10	0	25	3	45	2/1	2/1	3
French	12#	12# Heavy Artillery p	-5	-3	f	f	k	k	6	~	30	+2	23	5	35	6/1	1/1	5
French	6#	6# Horse Artillery p	-5g	-3g	f	f	k	k	6	~	23	+2	30	10	53	4/1	1/1	8
Poland	LC	Light Cavalry h	-2g	0g	~	+4	2	3	6	B	~	~	38	35	60	3/1	2/1	15
Poland	KRC	Krakus Cavalry h	-3g	-1g	~	+3	2	3	5	B	~	~	40	38	63	2/1	2/1	20
Poland	LN	Line Infantry	-2	+1	+6	-5	2	3	5	B	10	0	25	5	40	2/1	2/1	5
Poland	12#	12# Heavy Artillery p	-5	-3	f	f	k	k	5	~	30	+1	23	5	35	6/1	1/1	5
Poland	6#	6# Horse Artillery p	-5g	-3g	f	f	k	k	5	~	23	+1	30	10	53	4/1	1/1	8
Württemberg	LC	Light Cavalry h	-2g	0g	~	+4	2	3	5	B	~	~	38	35	60	3/1	2/1	17
Saxony	HC	Heavy Cavalry	+1g	+2g	~	+5	2	3	7	A	~	~	33	30	53	4/1	3/1	17
Saxony	6#	6# Horse Artillery p	-5g	-4g	f	f	k	k	4	~	23	0	30	8	53	4/1	1/1	8

*Dragoons from Spain

Austrain	HC	Heavy Cavalry	+1g	+2g	~	+6	2	4	6	B	~	~	33	30	50	4/1	3/1	13
Austrain	LC	Light Cavalry h	-2g	0g	~	+4	2	3	5	C	~	~	38	35	60	3/1	2/1	17
Austrain	LN	Line Infantry	-2	+1	+5	-5	2	4	5	D	10	0	23	5	40	2/1	2/1	5
Austrain	GRZ	Grenz Infantry s	-2	0	+5	-6	2	3	5	D	13	+1	30	5	45	3/2	4/3	5
Austrain	JG	Jager Infantry s	-2	0	+6	-5	2	4	5	C	13	+2	30	10	45	3/2	4/3	5
Austrain	12#	12# Heavy Artillery p	-5	-3	f	f	k	k	5	~	30	+1	23	5	35	6/1	1/1	5
Austrain	6#	6# Horse Artillery p	-5g	-3	f	f	k	k	5	~	23	+1	25	8	45	4/1	1/1	8
Prussian	HC	Heavy Cavalry	+1g	+2g	~	+6	2	4	6	B	~	~	33	30	50	4/1	3/1	13
Prussian	LC	Light Cavalry h	-1g	+1g	~	+4	2	3	6	C	~	~	38	35	60	3/1	2/1	18
Prussian	LWC	Landwehr Cavalry h	-3g	-1g	~	+3	1	3	5	D	~	~	35	33	60	4/1	3/1	17
Prussian	LN/RES	Line/Reserve Infantry	-1	+2	+7	-4	2	4	6	C	10	0	25	8	40	2/1	2/1	5
Prussian	SLW	Silesian Landwehr	-2	+1	+6	-5	2	3	5	D	10	0	23	5	40	3/1	2/1	5
Prussian	12#	12# Heavy Artillery p	-5	-3	f	f	k	k	6	~	30	+1	23	5	35	6/1	1/1	5
Prussian	HFA	Howitzer Artillery p	-5	-3	f	f	k	k	6	~	20	+1	25	8	35	4/1	1/1	8
Prussian	6#	6# Horse Artillery p	-5g	-3g	f	f	k	k	6	~	23	+1	28	10	53	4/1	1/1	8
Russian	LC	Light Cavalry h	-2g	0g	~	+3	2	3	5	C	~	~	38	35	60	3/1	3/1	20
Russian	CLC	Cossack Cavalry h *	-4g	-2g	~	+2	1	2	4	E	~	~	43	40	65	2/1	2/1	20
Russian	LN	Line Infantry	-2	+1	+6	-4	2	5	4	C	8	-1	23	5	40	2/1	2/1	5
Russian	JG	Jager Infantry	-2	0	+6	-4	2	4	5	C	10	0	25	10	45	2/1	2/1	5
Russian	12#	12# Heavy Artillery np	-5	-3	f	f	k	k	4	~	30	0	20	5	35	6/1	1/1	5
Russian	6#	6# Horse Artillery np	-5g	-3g	f	f	k	k	4	~	23	0	28	8	53	4/1	1/1	8

LIEBERWOLKITZ LABELS

F [18M] 35(23)E(10)+2 Murat	II [5F] 20G(5)+1 Victor	4/II 10E(7)+0 Dubreton	5/II 8P(5)+0 Dufour	6/II 8A(6)+0 Vial	22L/IIIC 8A(6)+0 Bruno	V [4F] 20G(5)+1 Lauriston
10/V 8G(8)+1 Albert	16/V 10G(8)+1 Maison	19/V 10A(6)+1 Rochambeau	6/VC 8A(6)+0 Dermoncourt	VIII [4F] 25G(7)+1 Poniatowski	26/VIII 8G(5)+1 Kamiemcki	27L/VIIC 10G(6)+1 Uminski:
IC [4F] 15G(6)+1 Lat.-Mauborg	1C/IC 10A(5)+0 Berckheim	3C/IC 10G(5)+0 Chastel	1CC/IC 10A(6)+0 Bordesoulle	3H/IC 10G(7)+1 Doumerc	IVC [2F] 15G(6)+1 Sokolnicki	7C/IVC 8A(5)+0 Tolinski
8C/IVC 10A(5)+0 Sulkowski	VC [3F] 13G(6)+1 Pajol	9C/VC 8G(5)+1 Subservie	5H/VC 10G(6)+1 Heritier	6H/VC 8G(7)+1 Milhaud		
1B/4II [12D] 24 FrLT	2B/4/II [12D] 24 FrPLN	1B/5/II [8D] 16 FrLT	2B/5/II [10D] 20 FrPLN	1B/6/II [12D] 24 FrLN	2B/6/II [12D] 24 FrLN	1B/22LC [3D] 8 WtLC
II Fr 12#	II Fr 12#	II Fr 6#	II Fr 6#	1B/10/V [14D] 28 FrLN	1B/16/V [14D] 28 FrLN	1B/19/V [8D] 16 FrLN
2B/19/V [8D] 16 FrLN	1B/6/VC [4D] 8 FrLC	V Fr12#	V Fr12#	V Fr6#	1B/26/VIII [8D] 20 PdLN	2B/26/VIII [10D] 24 PdLN
1B/27/VIIC [3D] 8 PdKRC	VIII Pd12#	1B/1C/IC [4D] 8 FrLC	1B/3C/IC [4D] 8 FrLC	1B/1CC/IC [4D] 8 FrHC	2B/1CC/IC [2D] 8 SxHC	1B/3H/IC [4D] 8 FrHC
2B/3H/IC [3D] 8 FrDC	IC Fr6#	IC Fr6#	IC Fr6#	IC Fr6#	IC Sx6#	

LIEBERWOLKITZ LABELS

		1B/7C/IVC[4D] 10 PdLC	1B/8C/IVC[4D] 10 PdLC	IVC Fr6#	IVC Pd6#	IVC Pd6#
1B/9C/VC [4D] 8 FrLC	2B/9C/VC [4D] 8 FrLC	1B/5H/VC [4D] 10 FrDC	1B/6H/VC [4D] 10 FrDC	VC Fr6#		

LIEBERWOLKITZ LABELS

B [20M] 50(27)A(10)+0 Schwarzenberg	IIP [5F] 23G(7)+1 Kleist	9/IIP 8P(4)+0 Klux	10/IIP 10G(7)+1 Pirch	11/IIP 8A(4)+0 Carnall	12/IIP 8A(4)+1 Preussen	C/IIP 10G(6)+1 Roder
RW 33G(6)+1 Wittgenstein	IR [2F] 18G(5)+1 Gortchakov	5/IR 8P(4)+0 Mesenzov	14/IR 8G(6)+0 Helfrich	IIR [1F] 20G(7)+1 Eugene	CSK [3F] 15E(7)+2 Platov	IVA [7F] 20G(6)+1 Klenau
2L/IVA 10G(8)+0 Bubna	1/IVA 10A(6)+0 Mohr	2/IVA 8G(4)+0 Bartenstein	3/IVA 8A(5)+0 Mayer	RCR [3F] 13G(7)+1 Pahlen	LC/RCR 8A(6)+0 Lissanevitch	D/RCR 10G(8)+1 Zeiten
3/IIR 8A(4)+0 Chakhovsky	4/IIR 8A(4)+0 Puchinzki					
1B/9/IIP [8D] 16 PrLN	1B/9/IIP [8D] 16 PrRES	1B/10/IIP [8D] 16 PrLN	1B/10/IIP [10D] 16 PrSLW	1B/11/IIP [8D] 16 PrLN	2B/11/IIP [8D] 16 PrRES	1B/12/IIP [8D] 16 PrLN
2B/12/IIP [8D] 16 PrLN	1B/C/IIP [4D] 10PrHC	2B/C/IIP [5D] 8PrLWC	IIP Pr#12	IIP Pr#HFA	IIP Pr#6	IIP Pr#6
1B/5/IR [8D] 16RsLN	2B/5/IR [8D] 16RsJG	1B/14/IR [8D] 16RsLN	IR Rs#12	IR Rs#12	IR Rs#12	IR Rs#12
IR Rs#6	IR Rs#6	IR Rs#6	IR Rs#6	1B/3/IIR [10D] 20RsLN	1B/4/IIR [10D] 20RsLN	IIR Rs#12
IIR Rs#12	IIR Rs#12	IIR Rs#12	IIR Rs#6	IIR Rs#6	IIR Rs#6	IIR Rs#6

LIEBERWOLKITZ LABELS

1B/CSK [7D] 10 RsCLC	2B/CSK [7D] 10 RsCLC	3B/CSK [6D] 8 RsCLC	4B/CSK [8D] 12 RsCLC	5B/CSK [7D] 10 RsCLC	CSK Rs#6	CSK Rs#6
1B/2L/IVA[14D] 24 AsGRZ	2B/2L/IVA[8D] 16 AsJG	3B/2L/IVA [5D] 10AsLC	4B/2L/IVA [6D] 12AsLC	2L/IVA As6#	2L/IVA As6#	
1B/1/IVA [14D] 24AsGRZ	2B/1/IVA [4D] 8AsLC	3B/1/IVA [4D] 8AsLC	1/IVA As6#	1/IVA As6#	1B/2/IVA [10D] 16AsLN	2B/2/IVA [12D] 20AsLN
3B/2/IVA [12D] 20AsLN	1B/3/IVA [14D] 24AsLN	2B/3/IVA [14D] 24AsLN	3B/3/IVA [3D] 8AsHC	IVA As12#	1B/LC/CRC [4D] 8RsLC	2B/LC/CRC [8D] 12RsCLC
3B/LC/CRC [7D] 10RsCLC	LC/CRC Rs#6	LC/CRC Rs#6	1B/D/RCR [4D] 8 PrLC	2B/D/RCR [4D] 8 PrLC	D/RCR Pr6#	